

# Product Catalog

TO ORDER

(800) 755-1950 or [premier@kgpco.com](mailto:premier@kgpco.com)

## TABLE OF CONTENTS

- » Broadband Coax Products
- » Data Products
- » Personal Protective Equipment (PPE)
- » Tools and Supplies
- » Tracer Wire

# Broadband Coax Products

- » BNC Crimp Connector Kit
- » CATV Coax Cable and Station Wire
- » CATV Digital Coax Splitter
- » MoCA Broadband Coax Splitters
- » Standard CATV Coax Splitter



# PREMIER RG59/6 BNC CRIMP CONNECTOR KIT

PREMIER's BNC hex crimp connectors for terminating RG59 or RG6 coaxial cable.

- Includes 2 ferrules which allow for easy installation on RG59 or RG6 coaxial cable
- Designed to work with any standard hex crimping tool
- High performance BNC connector
- Bandwidth: 0 MHz to 3 GHz
- Impedance: 75 Ohms

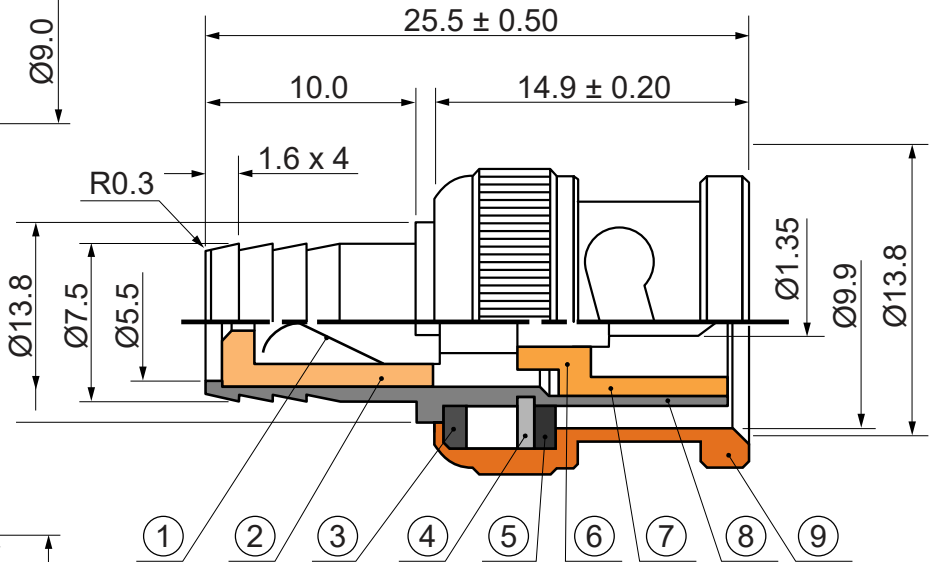
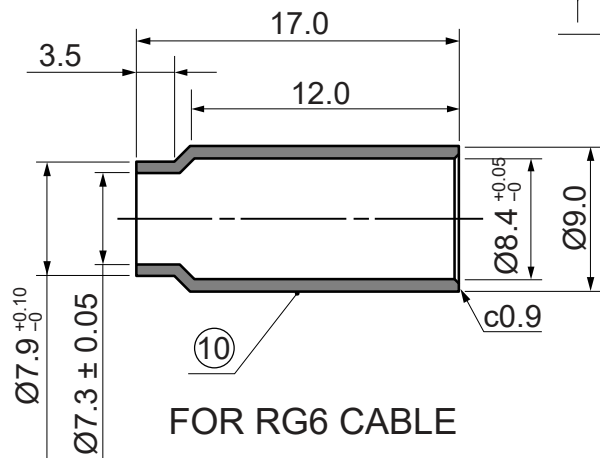
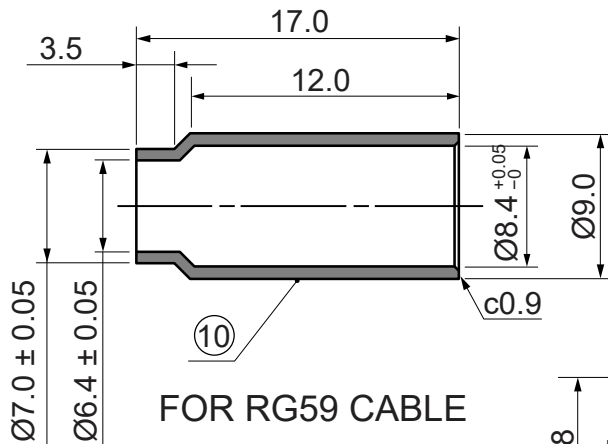

10	Ferrule	Zinc-alloy	Nickel
9	Shell	Zinc-alloy	Nickel
8	Body	Brass	Nickel
7	Insulator	ABS	
6	Pin	Brass	Gold
5	O-Ring	Silicon	
4	Washer 1	Iron	Nickel
3	Washer 2	Brass	Nickel
2	O-Ring	Silicon	
1	Inner Conductor	Phosphor bronze	Nickel
No.	PART	MATERIAL	PLATING

ITEM ID	PART#	DESCRIPTION
0000494875	PT-BNC-RG59/6	BNC hex crimp connectors for terminating RG59 or RG6 coaxial cable

Ask your PREMIER Account Representative for more details and place your order today. Call 800-755-1950.



## Station Wire

Station wire is constructed with a tough PVC jacket for indoor/outdoor applications that provides additional protection when exposed to outside weather conditions. Station wire is made from 22 or 24 gauge solid bare copper conductors that are individually insulated with semi-rigid PVC. Station wire is available in Category 3 or Category 5e.

Item No.	Mfg. Part No.	Description
2010827500	SW-C3X-2P22BG-P1000	2 Pair 22 Gauge CMX Category 3 1000 Foot Pop Box Beige
3043867500	SW-C3X-2P24BG-P1000	2 Pair 24 Gauge CMX Category 3 1000 Foot Pop Box Beige
3043887500	2137142	4 Pair 24 Gauge CMX Category 3 1000 Foot Pop Box Beige
0000014266	2137146E	4 Pair 24 Gauge CMX Category 5e 1000 Foot Pop Box Gray
0000185515	2137144E	4 Pair 24 Gauge CMX Category 5e 1000 Foot Pop Box Beige
0000282004	2137113E	4 Pair 24 Gauge CMX Category 5e 600 Foot Pop Box Ivory
0000031726	51-240-31	4 Pair 24 Gauge CMX Category 5e 1000 Ft Pop Box Gray-Superior Essex

## CATV Coax Cable

CATV Coaxial Cables are used for Radio Frequency (RF) signal transmission in broadband cable television applications. These coaxial cables are designed for low loss signal transmission and are available with a variety of shielding options in general purpose, riser and plenum constructions.

- 18 Gauge Solid Copper Clad Steel
- 60% Aluminum Braid Shield
- 75-ohm nominal impedance

Item No.	Mfg. Part No.	Description
0000108097	C5775.31.01	RG6 Coax General Purpose CM 60% Braid 1000 Foot Pop Box Black
0000233798	C5775.31.02	RG6 Coax General Purpose CM 60% Braid 1000 Foot Pop Box White
0000196741	C5775.41.01	RG6 Coax General Purpose CM 60% Braid 1000 Foot Reel Black

Ask your PREMIER Account Representative for more details and place your order today. Call 800-755-1950.



# PREMIER® CATV

## Digital Coax Splitter - 5-1000 MHz

PREMIER SCTE compliant CATV digital splitters provide the performance to exceed the high speed networking capacity and reliability required for high definition video streaming, internet services, and gaming in residential and multi-dwelling applications.

### Features and Benefits

- » Excellent return loss and port-to-port isolation in the return band.
- » Built-in 6kv ring wave and combo wave surge protection.
- » Machine threaded flat "F" ports.
- » Gold plated 360° contacts engineered for maximum contact and superior retention. Copper construction helps prevent common path distortion & impedance.
- » Ports are weather-sealed to 15 PSI to prevent moisture ingress.
- » Solid zinc cast housing with bright tin triple plating for durability in all environments.
- » Tin-plated copper back plate provides minimum -130dB shielding effectiveness and superior defense against long-term corrosion factors.
- » Stainless steel universal drive mounting screws and ground port screws included.
- » Low intermodulation distortion and protection against ferrites saturation.
- » Enhanced 15-42MHz return path for superior output return loss and port to port isolation performance.
- » Ultra linear ferrites prevent inter-modulation where high level return carriers can affect forward path performance.
- » 6 kV High grade voltage blocking capacitors on all ports to eliminate core saturation.
- » Superior intermodulation distortion and second harmonic performance.
- » Weather-sealed "F" ports.



### PREMIER® Digital Coax Splitter Specifications

- » 5-1000 MHz Bandwidth.
- » SCTE Compliant.
- » Operation temperature of -40°C to +60°C.
- » Meets or exceeds ANSI/SCTE 153 2008 for outdoor use and environmental and mechanical requirements.
- » Corrosion resistance, 1000 Hours of salt spray per ANSI/ SCTE 143 2007.
- » F connector, SCTE compliant IPS-SP-400.
- » Meets or exceeds SCTE IPS SP 217 R02.

### Ordering Information

ITEM ID	PART#	DESCRIPTION
0000438631	PT-DiGi-2W-1G	2-Way Horizontal Port Coax Splitter, 5-1000MHz bandwidth digital optimized, SCTE compliant.
0000438633	PT-DiGi-3WB-1G	3-Way Horizontal Port Coax Splitter, Balanced, 5-1000MHz bandwidth digital optimized, SCTE compliant.
0000438637	PT-DiGi-4W-1G	4-Way Horizontal Port Coax Splitter, 5-1000MHz bandwidth digital optimized, SCTE compliant.

Ask your PREMIER Account Representative for more details and place your order today. Call 800-755-1950.





# PREMIER® MoCA Broadband Coax Splitters - 5-1675 MHz

PREMIER MoCA 2.0 optimized coax splitters provide the performance to exceed the high speed networking capacity and reliability required for high definition video streaming, internet services, and gaming in residential and multi-dwelling applications.

## Features and Benefits

- » Excellent return loss and port-to-port isolation in the return band.
- » Built-in 6kv ring wave and combo wave surge protection.
- » Machine threaded flat “F” ports.
- » Gold plated 360° contacts engineered for maximum contact and superior retention. Copper construction helps prevent common path distortion & impedance.
- » Ports are weather-sealed to 15 PSI to prevent moisture ingress.
- » Solid zinc cast housing with bright tin triple plating for durability in all environments.
- » Tin-plated copper back plate provides minimum -130dB shielding effectiveness and superior defense against long-term corrosion factors.
- » Stainless steel universal drive mounting screws and ground port screws included.
- » Low intermodulation distortion and protection against ferrites saturation.
- » Enhanced 15-42MHz return path for superior output return loss and port to port isolation performance.
- » Ultra linear ferrites prevent inter-modulation where high level return carriers can affect forward path performance.
- » 6 kV High grade voltage blocking capacitors on all ports to eliminate core saturation.
- » Superior intermodulation distortion and second harmonic performance.
- » Weather-sealed “F” ports.

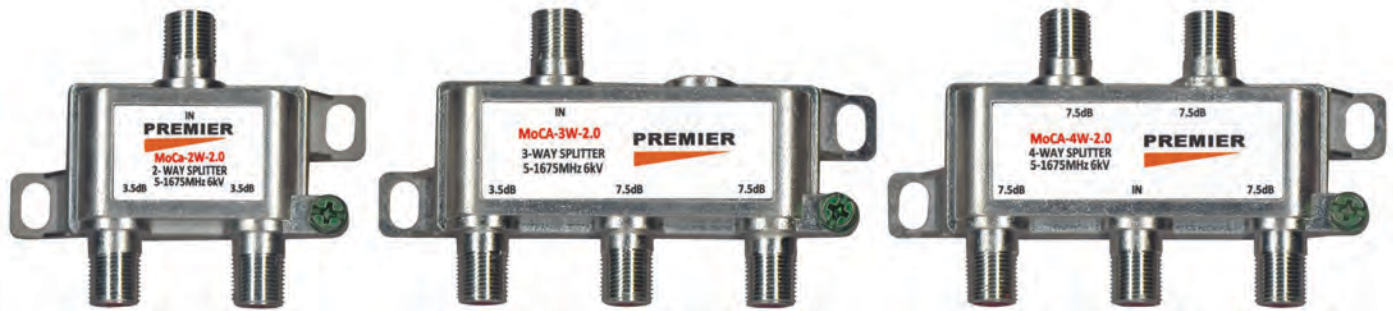

## PREMIER® MoCA Broadband Coax Splitter Specifications

- » 5-1675 MHz Bandwidth.
- » MoCA 2.0 Compliant
- » 2nd Harmonics/ Typical -55 dBmv, Min -45 dBmv.
- » Operation Temperature of -40°C to +60°C.
- » Meets or exceeds ANSI/SCTE 153 2008 for outdoor use and environmental and mechanical requirements.
- » Corrosion resistance, 1000 Hours of salt spray per ANSI/ SCTE 143 2007.
- » F connector, SCTE compliant IPS-SP-400.
- » Meets or exceeds SCTE IPS SP 217 R02.

## Ordering Information

Item Number	Part Number	Description
0000438656	PT-MoCA-2W-2.0	2-Way Horizontal Port Coax Splitter, 5-1675 MHz bandwidth, MoCA 2.0 optimized.
0000438657	PT-MoCA-2WV-2.0	2-Way Vertical Port Coax Splitter, 5-1675 MHz bandwidth, MoCA 2.0 optimized
0000438658	PT-MoCA-3WB-2.0	3-Way Horizontal Port Coax Splitter, Balanced, 5-1675 MHz bandwidth, MoCA 2.0 optimized
0000438659	PT-MoCA-3W-2.0	3-Way Horizontal Port Coax Splitter, Unbalanced, 5-1675 MHz bandwidth, MoCA 2.0 optimized
0000438660	PT-MoCA-3WVB-2.0	3-Way Vertical Port Coax Splitter, Balanced, 5-1675 MHz bandwidth, MoCA 2.0 optimized
0000438661	PT-MoCA-3WV-2.0	3-Way Vertical Port Coax Splitter, Unbalanced, 5-1675 MHz bandwidth, MoCA 2.0 optimized
0000438662	PT-MoCA-4W-2.0	4-Way Horizontal Port Coax Splitter, 5-1675 MHz bandwidth, MoCA 2.0 optimized
0000438663	PT-MoCA-4WV-2.0	4-Way Vertical Port Coax Splitter, 5-1675 MHz bandwidth, MoCA 2.0 optimized
0000438664	PT-MoCA-6W-2.0	6-Way Vertical Port Coax Splitter w/Horizontal Input Port, 5-1675 MHz, MoCA 2.0 Compliant.
0000438665	PT-MoCA-8W-2.0	8-Way Vertical Port Coax Splitter w/Horizontal Input Port, 5-1675 MHz, MoCA 2.0 Compliant.

Ask your KGPCo Customer Service Representative for more details and place your order today. 800-755-1950.

# PREMIER® MoCA Broadband Coax Splitters 5-1675 MHz

## MoCA Horizontal Splitters

Parameter		Bandwidth (MHz)	MoCA-2W		MoCA-3W		MoCA-4W			
			QC	TYP	QC	TYP	QC	TYP		
Insertion Loss (Max)		5-10 MHz	3.6	3.3	3.5/7.2	3.3/7.0	7.2	7.0		
		11-500 MHz	3.6	3.4	3.6/7.2	3.4/7.0	7.2	7.0		
		501-750 MHz	3.7	3.5	3.7/7.2	3.5/7.0	7.2	7.0		
		751-1002 MHz	3.8	3.6	3.8/7.5	3.7/7.2	7.2	7.5		
		1003-1100 MHz	4.9	4.2	4.0/7.8	3.8/7.5	8.2	8.0		
		1101-1675 MHz	6.8	5.5	5.5/11.0	5.5/10.5	11.0	10.5		
Isolation Loss Out-Out		Min		5-15 MHz	22	28	20	22	25	22
				16-42 MHz	30	38	20	22	35	23
		Max		43-500 MHz	26	28	18	20	26	20
				501-750 MHz	24	26	18	20	24	20
				751-1002 MHz	24	25	18	20	24	20
				1003-1200 MHz	25	25	25	25	25	25
				1201-1675 MHz	25	25	25	25	25	25
				Return Loss (Min) Input	5-15 MHz	22	22	20	21	18
16-42 MHz	23	25	23	24	23	24				
43-500 MHz	20	23	18	20	20	23				
501-750 MHz	18	20	15	16	18	20				
751-1002 MHz	18	20	14	16	18	20				
1003-1200 MHz	15	15	12	15	15	16				
1201-1675	12	15	10	12	10	12				

## MoCA Vertical Splitters

Parameter		Bandwidth (MHz)	MoCA-2WV		MoCA-3WV		MoCA-4WV		MoCA-6WV		MoCA-8WV			
			QC	TYP	QC	TYP	QC	TYP	QC	TYP	QC	TYP		
Insertion Loss (Max)		5-10 MHz	3.6	3.3	3.5/7.2	3.3/7.0	7.2	7.0	10.5	10.0	10.5	10.0		
		11-500 MHz	3.6	3.4	3.6/7.2	3.4/7.0	7.2	7.0	11.0	10.5	11.0	10.5		
		501-750 MHz	3.7	3.5	3.7/7.2	3.5/7.0	7.2	7.0	11.5	11.5	11.5	11.5		
		751-1002 MHz	3.8	3.6	3.8/7.5	3.7/7.2	7.2	7.5	12.0	12.0	12.0	12.0		
		1003-1100 MHz	4.9	4.2	4.0/7.8	3.8/7.5	8.2	8.0	14.0	13.5	14.0	13.5		
		1101-1675 MHz	6.8	5.5	5.5/11.0	5.5/10.5	11.0	10.5	19.0	18.0	19.0	18.0		
Isolation Loss Out-Out		Min		5-15 MHz	22	28	20	22	25	22	22	28	25	22
				16-42 MHz	30	38	20	22	35	23	25	28	25	28
		Max		43-500 MHz	26	28	18	20	26	20	23	25	23	25
				501-750 MHz	24	26	18	20	24	20	22	22	22	22
				751-1002 MHz	24	25	18	20	24	20	20	22	20	22
				1003-1200 MHz	25	25	25	25	25	25	33	33	33	33
				1201-1675 MHz	25	25	25	25	25	25	35	35	35	35
				Return Loss (Min) Input	5-15 MHz	22	22	20	21	18	20	17	18	17
16-42 MHz	23	25	23	24	23	24	23	25	23	24				
43-500 MHz	20	23	18	20	20	23	20	23	20	23				
501-750 MHz	18	20	15	16	18	20	18	20	18	20				
751-1002 MHz	18	20	14	16	18	20	18	20	18	20				
1003-1200 MHz	15	15	12	15	15	16	10	15	10	16				
1201-1675	12	15	10	12	10	12	5	10	5	10				

Ask your PREMIER Account Representative for more details and place your order today. Call 800-755-1950.



# PREMIER® Standard CATV

## Coax Splitter - 5-1000 MHz

PREMIER Standard CATV splitters provide the performance to exceed the high speed networking capacity and reliability required for high definition video streaming, internet services, and gaming in residential and multi-dwelling applications.

### Features and Benefits

- » Excellent return loss and port-to-port isolation in the return band.
- » Machine threaded flat “F” ports are SCTE compliant.
- » Tin plated zinc cast housing.
- » -130dB RFI shielding.
- » Universal drive mounting screws and ground port screws included.
- » Low intermodulation distortion and protection against ferrites saturation.
- » Enhanced 15-42MHz return path for superior output return loss and port to port isolation performance.
- » Smaller housing for tight installation.
- » Glass PCB with micro strip design.
- » Special magnetism resistant ferrite core prevents saturation.

### PREMIER® Standard CATV Coax Splitter Specifications

- » 5-1000 MHz Bandwidth.
- » SCTE Compliant.
- » F connector, SCTE compliant IPS-SP-400.
- » Solder back -130dB RFI.

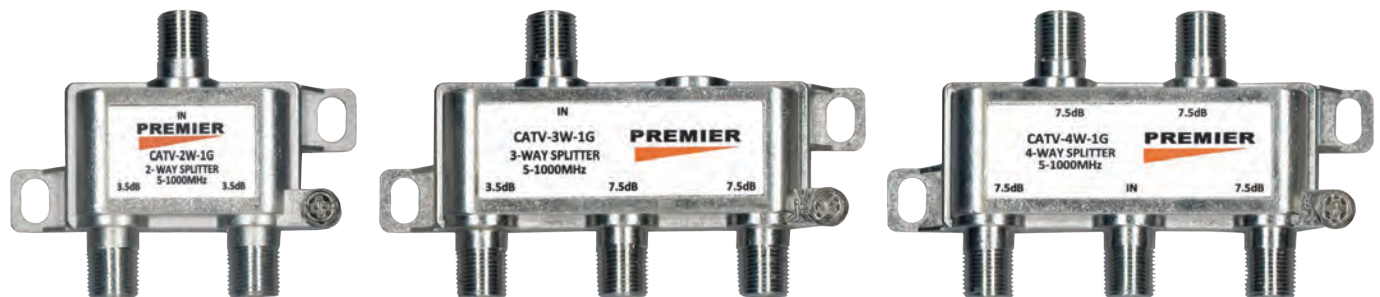

### Ordering Information

ITEM ID	PART#	DESCRIPTION
0000438666	PT-CATV-2W-1.0	2-Way Horizontal Port Coax Splitter, 5-1000 MHz bandwidth.
0000438669	PT-CATV-3W-1.0	3-Way Horizontal Port Coax Splitter, Unbalanced, 5-1000 MHz bandwidth
0000438672	PT-CATV-4W-1.0	4-Way Horizontal Port Coax Splitter, 5-1000 MHz bandwidth.
0000438674	PT-CATV-6W-1.0	6-Way Vertical Port Coax Splitter w/Horizontal Input Port, 5-1000 MHz.
0000438675	PT-CATV-8W-1.0	8-Way Vertical Port Coax Splitter w/Horizontal Input Port, 5-1000 MHz.

Ask your PREMIER Account Representative for more details and place your order today. Call 800-755-1950.



# PREMIER® Standard CATV Coax Splitters 5-1000 MHz

## Standard CATV Horizontal Splitters

SPECIFICATIONS									
PARAMETER	FREQUENCY RANGE MHz	CATV-2		CATV-3		CATV-3B		CATV-4	
		TYP	QC	TYP	QC	TYP	QC	TYP	QC
Insertion Loss (dB) (Max)	5-15	3.5	3.6	3.7/6.9	3.8/7.0	5.6	5.8	7	7.1
	16-40	3.6	3.7	3.7/6.9	3.8/7.0	5.6	5.8	6.8	6.9
	41-450	3.7	3.8	3.7/7.0	3.8/7.0	6.2	6.5	7	7.1
	451-750	3.8	3.9	3.9/7.5	4.0/7.6	6.3	6.5	7.5	7.6
	751-1000	3.9	4	4.0/8.0	4.2/8.2	6.9	7	8.1	8.2
Isolation (dB)	5-15	26	25	30	22	25	20	30	22
	16-40	45	40	38	35	38	35	40	32
	41-450	31	30	30	25	28	25	30	25
	451-750	31	30	28	25	25	23	28	25
	751-1000	30	25	25	23	22	20	25	23
Input Return Loss (dB) (Min)	5-15	25	24	25	20	22	20	25	20
	16-40	26	25	28	24	25	22	28	24
	41-450	26	25	28	23	25	22	28	23
	451-750	26	25	28	20	23	20	25	20
	751-1000	25	22	24	20	22	20	21	20
Output Return Loss (dB) (Min)	5-15	26	24	25	22	24	20	25	20
	16-40	35	30	35	30	32	28	30	28
	41-450	26	25	30	23	25	22	28	23
	451-750	26	25	25	20	22	20	25	20
	751-1000	25	22	24	20	22	20	21	20

## Standard CATV Vertical Splitters

SPECIFICATIONS											
PARAMETER	FREQUENCY RANGE MHz	CATV-2V		CATV-3V		CATV-4V		CATV-6V		CATV-8V	
		TYP	QC	TYP	QC	TYP	QC	TYP	QC	TYP	QC
Insertion Loss (dB) (Max)	5-15	3.3	3.5	3.5/6.8	3.6/6.9	6.8	6.9	9.1	9.2	10	10.5
	16-40	3.3	3.5	3.5/6.9	3.6/7.0	6.9	7	9.1	9.2	10.3	10.8
	41-450	3.6	3.8	3.8/7.4	3.9/7.5	7.4	7.5	9.9	10	11	11.5
	451-750	3.9	4.2	4.0/8.0	4.1/8.1	8	8	10.5	11	11.7	12.2
	751-1000	4	4.4	4.0/8.0	4.2/8.2	8.1	8.2	11.3	11.5	12.2	12.5
Isolation (dB)	5-15	26	20	35	23	29	24	24	23	30	25
	16-40	33	25	38	25	29	25	25	24	30	24
	41-450	35	22	36	22	30	25	23	22	25	22
	451-750	32	20	30	22	28	24	22	20	23	21
	751-1000	28	20	25	20	27	24	21	20	22	20
Input Return Loss (dB) (Min)	5-15	24	20	21	19	22	18	19	18	22	18
	16-40	27	22	23	21	24	20	21	20	25	22
	41-450	23	20	23	20	25	21	21	20	24	20
	451-750	24	18	22	20	22	18	20	18	23	19
	751-1000	24	18	21	18	21	18	19	18	22	18
Output Return Loss (dB) (Min)	5-15	22	20	20	18	21	18	17	16	22	18
	16-40	28	22	32	20	25	22	21	20	28	22
	41-450	31	20	26	20	28	25	21	20	24	20
	451-750	30	20	22	18	23	18	20	18	23	19
	751-1000	25	20	20	18	21	18	19	18	22	19

Ask your PREMIER Account Representative for more details and place your order today. Call 800-755-1950.



# Data Products

- » ADSL POTS Splitter Outdoor Ancillary Device
- » Transceivers
- » xDSL over POTS Inline and Slim Inline Filters



# PREMIER®

## ADSL POTS Splitter - Outdoor Ancillary Device

The PREMIER ADSL POTS (Plain Old Telephone Service) Splitter Outdoor Ancillary Device is a passive unit which allows both voice and data signals to transmit separately over telephone lines. This device can be mounted externally on a wall or conduit. With wiring terminals for each of three splitter ports in an environmentally hardened casing, the PREMIER ADSL POTS Splitter is extremely versatile and durable.



### Features & Benefits

- » Outdoor housing with environmental protection
- » Wall or conduit mounting options
- » Wiring terminals for each splitter port (Network, Data, Voice)
- » ANSI T1.413 compliant
- » UL-listed to U.S. and Canadian safety standards
- » FCC registered; Part 68 compliant
- » Provides network test signatures
- » Can be mounted in wiring closet
- » Simple screw terminal installation

### Ordering Information

Item Number	Part Number	Description
0000161278	PT-DSL-OD-SPLIT	ADSL POTS Splitter

Ask your PREMIER Account Representative for more details and place your order today. Call 800-755-1950.



## PREMIER® ADSL Technical Specifications

### Electrical (Complies with ANSI T1.413 Issue 2 Annex E)

DC Loop Current.....	0 to 100 mA
DC Loop Voltage (tip-to-ring).....	0 to - 60 VDC
Ringing Signals.....	103 Vrms superimposed on the DC Loop Voltage, 20 to 30 Hz
DC Resistance.....	≤ 25 ohms,POTS tip-to-ring with Line port (U-R) shorted
Insertion Loss.....	≤ 1.0 dB; short loop, ZTc=900, ZTr=600, 1004 Hz ≤ 0.75 dB; long loop, ZTc=900, ZTr=600, 1004 Hz
Attenuation Distortion (Voice Band) ..... increase relative to Insertion Loss at 1004 Hz	+1.5 to -1.5; 0.2 -3.4 kHz, short loop, ZTc=900, ZTr=600 +2.0 to -2.0; 3.4 - 4.0 kHz, short loop, ZTc=900, ZTr=600 -0.5 to -1.5; 0.2 - 4.0 kHz, long loop, ZTc=900, ZTr=600
Delay Distortion (Voice Band) increase.....	≤ 200μs; 0.6 - 3.2 kHz, short loop, ZTc=900, ZTr=600 ≤ 250μs; 0.2 - 4.0 kHz, short loop, ZTc=900, ZTr=600 ≤ 200μs; 0. - 3.2 kHz, long loop, ZTc=900, ZTr=600 ≤ 250μs; 0.2 - 4.0 kHz, long loop, ZTc=900, ZTr=600
Return Loss (Voice Band).....	>6 dB ERL, > 5 dB SRL-L, > 3dB SRL-H; short and long loop >2 dB SRL-H; short and long loop, single frequency
Longitudinal Balance, Two Port Technique.....	>58 dB; 0.2-1.0 kHz
POTS to Line Port (U-R) and Line Port (U-R).....	>straight line from 58 dB @ 1 kHz to 53 dB @3.0 kHz, to POTS Bias 25 mA DC
Tip-to-Ring Capacitance, POTS Port.....	20 ≤ C ≤115 nF;20 - 30 Hz (Note:T1.413 Issue 2 requires ≤ 90 nF, plans are to increase this in Issue 3 to ≤ 115 nF)
Capacitance to Ground, POTS Port.....	≤1.0 nF; 20 - 30 Hz
ADSL Band Attenuation.....	>65 dB; 30 - 300 kHz, ZTr=600 >55 dB; 300 -104 kHz, ZTr=600
Input Impedance.....	≤0.25 dB; 30 -1104 kHz, ZTr=600

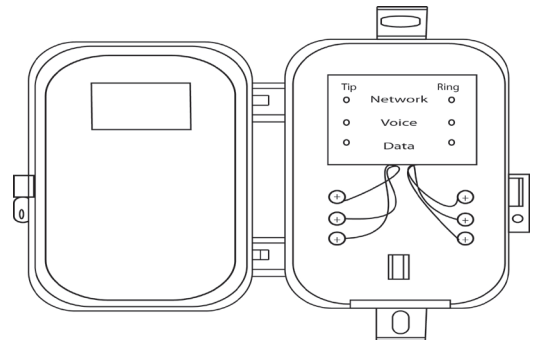

### Environmental

Lightning Surge.....	GR-1089-CORE Level 1 and Level 2 surge
Power Cross.....	GR-1089-CORE First and Second Level AC Power Fault Immunity
Operating Temperature.....	-40 to +65°C (-40 to 149°F)
Relative Humidity.....	0 to 95%, non-condensing

### Safety

UL-listed to U.S. and Canadian safety standards

FCC Part 68 compliant

Ask your PREMIER Account Representative for more details and place your order today. Call 800-755-1950.



# PREMIER Transceivers

OEM Compatible Optics



SFP  
SFP+  
GBIC  
GPON  
QSFP+  
QSFP28  
XENPAK  
X2  
XFP  
CFP

## PREMIER OEM Compatible Optics

- » Coded for Identical Functionality to OEM Products
- » Significant Savings compared to OEM Products
- » 100% Individual OEM Specific Testing for Guaranteed Compatibility
- » Spirent® Test Center for Traffic Simulation Functionality Testing
- » Effortless Integration with OEM and Third-Party Products
- » Increased Scalability and Flexibility
- » Custom Solutions not offered by OEM

## Why PREMIER

### PREMIER products perform identical to the OEM

Supported Display with full System Recognition and Optical Monitoring Diagnostics

### PREMIER products will not void the OEM warranty or service agreement

PREMIER supports over 8000 OEM Compatible Solutions from 1GB to 100GB

## LIFETIME WARRANTY

Ask your PREMIER Account Representative for more details and place your order today. Call 800-755-1950.



## Features and Benefits

- » Peace of Mind - PREMIER products will NOT void the OEM Warranty agreement or SLA
- » Carrier Grade Without Compromise - Reduce acquisition cost and maximize budget
- » Prolong Network Lifestyles - Current and legacy platforms supported
- » Expansive Product Offering - Over 8000 network connectivity products
- » Just In-Time Delivery - Most products are available for immediate shipment
- » Technical Support - Certified Technicians for pre/post-sales support
- » Comprehensive test lab contains the industry's leading network platforms
- » **LIFETIME WARRANTY**

## How to Order PREMIER Products

Order Configuration

PREMIER part number = PT-OEM PN

Example: Cisco GLC-SX-MMD



## Supported manufacturers include:

3Com • Accedian • ADTRAN • Adva • Aerohive • Alcatel-Lucent • Allied Telesis • Arista • Avaya • Blade Network • Brocade/Foundry • BTI • Calix • Ciena • Cisco • Coriant • Cyan • D-Link • Dell • EMC • Enterasys • Extreme Networks • F5 Networks • Force 10 • Fujitsu • Gigamon • H3C • Harmonic • Hatteras • HP • Huawei • IBM • Infinera • Intel • Juniper • Linksys • Marconi • Meraki • Moxa • NetApp • Netgear • Nokia • Nortel • Occam Networks • Palo Alto Networks • Siemens • SMC • Sun • Telco Systems • Tellabs • Zyxel



Ask your PREMIER Account Representative for more details and place your order today. Call 800-755-1950.



# PREMIER

## xDSL over POTS In-Line and Slim In-Line Filters

The PREMIER filters are designed to expedite the service delivery and improve the performance of digital subscriber line (DSL) services. These models filter all telephone sets, facsimile machines, answering machines, etc. individually or in groups. The DSL filters design electronically isolates the high-speed DSL data streams from the voice band POTS (plain old telephone service) equipment. This design effectively blocks the DSL, and other radio frequencies from 25 kilohertz to 30 Megahertz.



### Features

- » **Data Protection** - Isolates telephone impedance changes from DSL equipment
- » Excellent DSL band attenuation that protects voice band equipment and prevents inter-modulation distortion from degrading data rates
- » Compatible with all major DSL standards including ADSL, ADSL2+, VDSL, and VDSL2
- » **Voice Protection** - Isolates DSL band frequencies from voice band equipment
- » Excellent longitudinal balance
- » Compatible with Caller ID, facsimile and metallic loop testing
- » RoHS compliant
- » Compliant and listed with UL 60950, FCC Part 68
- » ETL certified

### Ordering Information

Item Number	Part Number	Description	
0000188943	PT-DSL-ILF-T	xDSL over POTS In-Line Filter	Includes a second convenience jack that is unfiltered for connecting DSL

Ask your PREMIER Account Representative for more details and place your order today. Call 800-755-1950.



## PREMIER Filter Specifications

Line side differential input blocking impedance		
At 20kHz		>2k
At 30kHz		>3k
From 5MHz to 10MHz		>2k
1kHz insertion loss between 600Ω resistive		
Single filter		<0.4
With 5 filters		<0.6
1kHz/2.8kHz slope between 600Ω resistive		
Single filter		<0.1
With 5 filters		<1.1
DC resistance in Ohms		
Tip to Tip, and Ring to Ring		<12
Tip to Ring		>10M
Longitudinal Balance per IEEE method		
From 200 - 1kHz		>58dB
From 1kHz - 3kHz		>53dB
Common mode rejection, 40kHz and 30MHz		
>45dB		
Low pass roll off (slope) between 600Ω and ADSL Transmission Unit - Remote		
>26dB		
Inter-Modulation Distortion First and Second order products		
>60dB		
Envelope Delay 300 Hz - 2800 Hz		
<100μs		
600Ω Return Loss into phone side with 600Ω line termination with ATU-R		
Single filter	SRL Low	>30dB
	ERL	>14dB
	SRL High	>17dB
+2 bridged filters	SRL Low	>36dB
	ERL	>23dB
	SRL High	>13dB
+4 bridged filters	SRL Low	>26dB
	ERL	>15dB
	SRL High	>8dB
Complex* Return Loss with ATU-R		
Single filter	SRL Low	>27dB
	ERL	>14dB
	SRL High	>6dB
+ 2 bridged filters	SRL Low	>19dB
	ERL	>14dB
	SRL High	>3dB
+ 4 bridged filters	SRL Low	>15dB
	ERL	>7dB
	SRL High	>2dB
*1330Ω in parallel with (100nfd in series with 348Ω)		
DC Loop Current - Meets specifications between 20 and 100 milliamps DC		
Connectors: RJ-11 Jacks and RJ-11 Plug.		
RJ11 pins have ≥50 micro-inches of gold plating over ≥100 micro-inches of nickel plating		
Compliant and listed with UL / CSA 60950, FCC CFR 47 Part 68		

Ask your PREMIER Account Representative for more details and place your order today. Call 800-755-1950.



# Personal Protective Equipment (PPE)

- » Hand Sanitizer
- » Sanitizer Dispensers
- » Hand Sanitizer Wipes
- » Nitrile Gloves
- » Shoe Covers



# Hand Sanitizer



**Call to Order (800) 755-1950**



8 oz. & 12 oz.  
Available with dispensing cap or spray top

**[15 bottles per case]**

**Product IDs**

8 oz.	12 oz.
Cap Gel: 0000528631	Cap Gel: 0000528633
Cap Non-gel: 0000528630	Cap Non-gel: 0000528632
Spray Non-gel: 0000528639	Spray Non-gel: 0000528640



18 oz. bottle  
Available with dispensing cap

**[30 bottles per case]**

**Product ID**

Gel: 0000528635
Non-gel: 0000528634



1 gallon jug  
with twist cap  
Pump top sold separately

**[4 jugs per case]**

**Product ID**

Gel: 0000528637
Non-gel: 0000528636
Pump top: 8800017231

Available in  
non-gel or  
gel-based  
sanitizer

See page 6 for product ingredients

# Sanitizer Dispensers



**Call to Order (800) 755-1950**



## Wall Mount/Tabletop Dispenser

- Tabletop or wall mount option
- Automatic, touchless dispensing
- Both battery & AC/DC power enabled
- 30,000 dispenses per battery set
- Dispenses liquid, spray or foam
- Compatible with PREMIER hand sanitizer
  - Holds 33 oz.
- Dimensions: 17"H x 5"W x 4"D

Optional wall mount back plate is available.

Dispenser Product ID	Wall Mount Back Plate
0000541433	0000541965



## Floor Mount Dispenser

- Sturdy, solid metal stand
- Adjustable stand height
- Automatic, touchless dispensing
- Both battery & AC/DC power enabled
- 30,000 dispenses per battery set
- Dispenses liquid, spray or foam
- Compatible with PREMIER hand sanitizer
  - Holds 33 oz.
- Dimensions: 59"H x 11"W x 16"D

Dispenser Product ID
0000541432

# Hand Sanitizer Wipes



**Call to Order (800) 755-1950**



Wipes Material: Disposable  
Non-woven; 40 GSM Wet  
Strength Paper

Sheet Size: 7.8 in. x 5.9 in.

Ingredients:  
75% Ethanol Alcohol, Aqua,  
Benzalkonium Chloride, Glycerin, Aloe  
Barbadensis, Leaf Extract

250 wipes per bucket

**Product ID**

**0000539904**

# Nitrile Gloves



**Call to Order (800) 755-1950**



5mil nitrile, single-use  
Powder-free  
Textured fingertips  
Non-sterile  
Ambidextrous  
Not made from natural rubber latex  
100 gloves per box  
Available in Medium  
and Large sizes

Size Medium	Size Large
0000543388	0000543389



# Shoe Covers



**Call to Order (800) 755-1950**



## Shoe Covers

Disposable  
Size XL  
Sold in rolls of 5; 10 rolls  
per bag

**Product ID**

0000537545



# Sanitizer Ingredients



**Call to Order (800) 755-1950**

## Non-gel hand sanitizer

Ethyl Alcohol (94.9%+ Purity): 80%

Distilled Water: 18.425%

Glycerin: 1.45%

Hydrogen Peroxide: 0.125%

## Gel hand sanitizer

Ethyl Alcohol (94.9%+ Purity): 80%

Distilled Water: 18.4%

Glycerin: 1%

Triethanolamine: 0.40%

Carbomer: 0.20%

# Tools and Supplies

- » Ant, Insect, Spider Control
- » Bare Fiber Adapter
- » Economy Grade Vinyl Electrical Tape
- » Fiber Optic Cleaning Ordering Guide
- » Hand Cleaner Towels
- » Hand Tools and Specialty Tools
- » Marking Paint
- » Outdoor Signs and Markers
- » Reflective Decal Lettering
- » Safety Wipes (sunscreen and bug repellent)
- » Splice Protection Sleeves
- » Splicing Supplies - Tape
- » Truper Tools
- » Wasp and Hornet Spray
- » Wireless Weatherproofing Kit



# NaturChem, Inc.

## HY-END Bifen ITP®

## HY-END Bifen S

### Fire Ant Control that is: Effective and Convenient.

**Effective** - HY-END Bifen controls Fire Ants where applied in and around telecommunication, power, utilities, and railroad systems equipment. The active ingredient Bifenthrin is the most effective product in the market today featuring the longest lasting residual control of insects in its class.

**Convenient** - The next generation of Fire Ant control is now available in convenient 4 oz packaging. Individual packages are shipped and stored in user friendly, waterproof buckets with 100 single application packets (4 bags of 25 packets) in each bucket. HY-END Bifen is also available in a 64 oz. shaker can with 8 cans per case.



## Applications

NaturChem's HY-END Bifen is labeled to be used for Fire Ant Control in and around the following locations:

- » Telecommunications equipment
- » Pad mounted transformers
- » Underground power cable splice boxes and vaults
- » Telephone pedestals and cables
- » A/C or air handling systems (around homes and commercial locations)
- » Traffic signal boxes
- » Railroad control/communications boxes
- » Electric and water meter boxes
- » Cable television pedestals
- » Runway lighting boxes, and lighting control buildings and boxes
- » Ground mounted utility cabinets
- » Utility poles
- » Boxes, closures, interfaces, protectors, terminals
- » Fire alarm systems, lights and alarms

## Ordering Information

Item Number	Part Number	Description
0000358307	HY-END Bifen ITP®	Fire Ant Control, Bucket of 100 4 oz packets - 4 bags of 25 packets in bucket - <a href="#">One 4 oz. packet covers 1 ft<sup>2</sup> (12"x12")</a>
0000291673	HY-END Bifen S	Fire Ant Control, 64oz Shaker Can - <a href="#">One can covers up to 266 ft<sup>2</sup></a>

Ask your PREMIER Account Representative for more details and place your order today. Call 800-755-1950.





## NaturChem HY-END Bifen ITP® & S

Bifen ITP	Features	Benefits
<b>Effective</b>	Active ingredient Bifenthrin is extremely effective on a wide variety of insects including spiders and 72 soil borne insects	Produces dependable results
<b>Specific</b>	Bifenthrin is especially effective on soil active insects	Ideal for fire ant control
<b>Enduring</b>	Very low water solubility giving rise to longevity in the soil (is a standard for treatment of termites)	Longevity and dependability
<b>Odorless active ingredient</b>	Non-corrosive and non-conductive	May be used in a variety of locations (refer to product label)
<b>Convenient</b>	Re-sealable bucket with 100 single application packets in each bucket or a 64oz. shaker can	Compact storage Protection from damage and moisture No measuring

Ask your PREMIER Account Representative for more details and place your order today. Call 800-755-1950.



# PREMIER®

## Bare Fiber Adapter

### Easier, faster, more efficient fiber testing

The PREMIER® Bare Fiber Adapter provides a temporary connection that eliminates the time consuming process of splicing jumpers onto individual fibers for testing. This allows you to easily test and detect fiber damage any where, any time. It will make fiber testing and network maintenance easier, faster and more efficient for technicians and contractors.

Unlike other adapters, the PREMIER® Bare Fiber Adapter is contained in a durable aluminum-alloy housing which is easy to stabilize on any magnetic surface for hands-free use. The fiber is held securely in place until you press the push button release and remove the fiber. If a fiber should break inside the unit, the fiber pieces can be easily removed by using the cleaning wire kit included with each Bare Fiber Adapter. A built-in compartment with a sliding door allows you to see inside the adapter to assist in fiber alignment and cleanout.

The PREMIER® Bare Fiber Adapter kit comes in a belt-hanger zipper case and includes everything needed to test any fiber optic cable. The kit includes:

- » PREMIER® Bare Fiber Adapter
- » Launch reel with 122m (400ft) of singlemode fiber and SC connectors
- » One meter SC singlemode fiber jumper
- » Zipper case with Carabiner clip
- » Cleaning wire kit
- » Operational guide

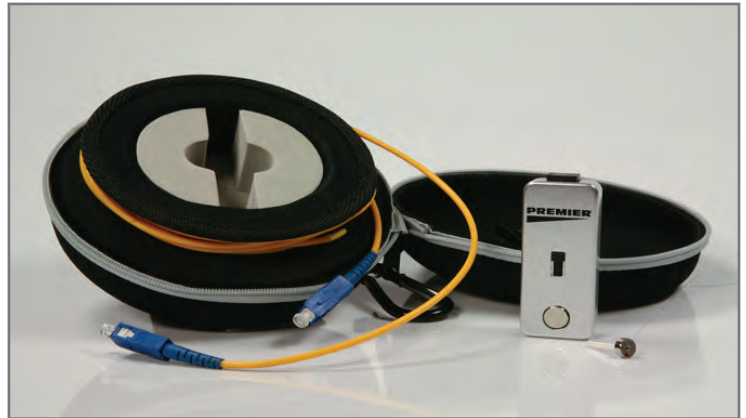

### Product Features

- » Durable aluminum-alloy housing
- » Simple, accurate, easy to use
- » Hands free with magnetic mount
- » Fiber retaining mechanism holds fiber in place
- » Commonly used SC connector port allows for replaceable jumper
- » Built-in compartment to assist in bare fiber alignment and removal of broken fibers
- » Matching gel not required

Ask your PREMIER Account Representative for more details and place your order today. Call 800-755-1950.



# PREMIER®

## Bare Fiber Adapter

### Benefits

- » Test any size or type of fiber
- » Test multiple strands in minutes
- » Test fiber on the reel before installation
- » Reduce trips to site
- » Reduce labor and contractor costs
- » Reduce wasted restoration time
- » Reduce customer outage duration

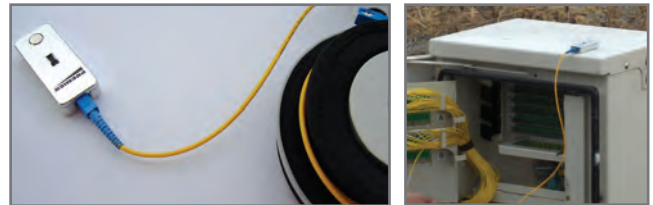

### Ordering Information

Item Number	Part Number	Bare Fiber Adapter	Zipper Case with Carabiner Clip	122m (400ft) Singlemode Fiber	Operation Guide	Cleaning Wire Kit	1m SC Fiber Jumper
0000202073	PT-BFA-KIT	X	X	X	X	X	X

Ask your PREMIER Account Representative for more details and place your order today. Call 800-755-1950.



# Economy Grade Vinyl Electrical Tape

PREMIER Economy Grade Vinyl Electrical Tape is a general purpose indoor and outdoor insulating tape that is both economical and durable.

## Applications

- Used for joining and splicing wires and cables for electrical insulation
- Indoor and outdoor insulating tape
- Suitable for uses under 600V or 80°C (176°F)
- Ideal for all applications where UL listed insulated materials are required.

## Features & Benefits

- Economical and Durable
- UL Listed
- 3/4" x 60' rolls available in several different colors
- One sided coating of rubber-based, pressure sensitive adhesives eliminates the need of heat, moisture, or other catalysts to affect application
- Soft PVC film coated tape; suitably plasticized and stabilized

## Technical Performance

Description	Units	Value	Test method
Tape thickness	mm/mils	0.18 / 7.0	PSTC-33
Adhesion to steel	kg/cm, oz/in	0.20 / 18	ASTM D-1000
Adhesion to backing	kg/cm, oz/in	0.20 / 18	ASTM D-1000
Elongation at break	%	200	PSTC-31
Tensile Strength	kg/cm, lbs/in	3.2 / 18	PSTC-31
Dielectric at Break	Volts/mil	1,250	ASTM D-1000



Ask your KGPCo Customer Service Representative for more details and place your order today. 800-755-1950.











## Ordering Information

Item Number	Part Number	Description
0000416546	97060	Black Vinyl Electrical Tape 3/4" x 60'
0000416547	97061	Red Vinyl Electrical Tape 3/4" x 60'
0000416548	97062	White Vinyl Electrical Tape 3/4" x 60'
0000416549	97063	Blue Vinyl Electrical Tape 3/4" x 60'
0000416550	97064	Green Vinyl Electrical Tape 3/4" x 60'
0000416551	97065	Grey Vinyl Electrical Tape 3/4" x 60'
0000416552	97066	Yellow Vinyl Electrical Tape 3/4" x 60'
0000416553	97067	Orange Vinyl Electrical Tape 3/4" x 60'
0000416554	97068	Brown Vinyl Electrical Tape 3/4" x 60'









Ask your PREMIER Account Representative for more details and place your order today. Call 800-755-1950.



## Fiber Optic Cleaning Ordering Guide

Sticklers P/N	PREMIER Item #	Description	Standard Lead Time
FK03	0000480213	<b>General Purpose CLEANKIT™ Cleaning Kits for Fiber Optic Splices &amp; Connectors</b> <ul style="list-style-type: none"> <li>Includes CLEANWIPES™ 600 box; CLEANWIPES™ 90 tub and Outdoor CLEANWIPES™ optical grade wipes</li> <li>Includes two cans of Fiber Optic Splice &amp; Connector Cleaner® cleaning fluid</li> <li>Includes CLEANSTIXX™ box with (30x 2.5mm sticks and 20x 1.25mm sticks)</li> <li>Includes LED Flashlight</li> </ul> 	Stock to 1 week
FK05	0000480215	<b>Military CLEANKIT™ Cleaning Kits for Fiber Optic Splices &amp; Connectors</b> <ul style="list-style-type: none"> <li>Includes CLEANWIPES™ 600 box; CLEANWIPES™ 90 tub; and Outdoor CLEANWIPES™ optical grade wipes</li> <li>Includes two cans of Fiber Optic Splice &amp; Connector Cleaner® cleaning fluid</li> <li>Includes CLEANSTIXX™ box with (10x 2.5mm/10x 1.25mm/10x Pin Termini/10XM MT/ 10X 1.6mm sticks)</li> <li>Includes LED Flashlight</li> </ul> 	Stock to 1 week
FK08	0000480214	<b>General Purpose CLEANKIT™ Cleaning Kits featuring the CLEANCLICKER® 750 cleaners for cleaning Fiber Optic Splices &amp; Connectors</b> <ul style="list-style-type: none"> <li>Includes CLEANWIPES™ 600 box; CLEANWIPES™ 90 tub; and Outdoor CLEANWIPES™ optical grade wipes</li> <li>Includes two cans of Fiber Optic Splice &amp; Connector Cleaner® cleaning fluid</li> <li>Includes CLEANSTIXX™ box with (30x 2.5mm sticks and 20x 1.25mm sticks)</li> <li>Includes LED Flashlight</li> </ul> 	Stock to 1 week
CCU250	0000480216	<b>2.5mm CLEANCLICKER® 750 Fiber Optic Cleaner</b> <ul style="list-style-type: none"> <li>750+ cleanings per unit and refillable - In Adapters &amp; Assemblies</li> <li>Cleans SC, FC, ST, E2000 &amp; OptiTap connectors with UPC &amp; APC polishes</li> <li>Uses refill part number CCR250</li> </ul> 	Stock to 1 week
CCR250	0000480217	<b>2.5mm CLEANCLICKER® 750 Fiber Optic Cleaner REFILL TWIN PACK</b> <ul style="list-style-type: none"> <li>Refill Cartridges for 2.5mm CLEANCLICKER 750 fiber optic connector cleaners</li> <li>There are two refill cartridges per box. Price is for a box of two cartridges.</li> <li>To replace cartridges, simply pull old cartridge nozzle to unsnap. Refill cartridge snaps into handle.</li> </ul> 	Stock to 1 week
CCU125	0000480218	<b>1.25mm CLEANCLICKER® 750 Fiber Optic Cleaner</b> <ul style="list-style-type: none"> <li>750+ cleanings per unit and refillable - In Adapter &amp; Assemblies</li> <li>Cleans LC &amp; MU connectors with UPC &amp; APC polishes</li> <li>Uses refill part number CCR125</li> </ul> 	Stock to 1 week
CCR125	0000480219	<b>1.25mm CLEANCLICKER® 750 Fiber Optic Cleaner REFILL TWIN PACK</b> <ul style="list-style-type: none"> <li>Refill Cartridges for 1.25mm CLEANCLICKER 750 fiber optic connector cleaners</li> <li>There are two refill cartridges per box. Price is for a box of two cartridges.</li> <li>To replace cartridges, simply pull old cartridge nozzle to unsnap. Refill cartridge snaps into handle.</li> </ul> 	Stock to 1 week
CCMPO	0000480220	<b>MPO CLEANCLICKER® 600 Fiber Optic Cleaner</b> <ul style="list-style-type: none"> <li>600+ cleanings per unit - In Adapter &amp; Assemblies</li> <li>Cleans MPO &amp; MTP connectors with guide pins (male) &amp; on trunk (female) assemblies</li> </ul> 	Stock to 1 week
CCWRC	0000484860	<b>Cassette CLEANCLICKER End Face Cleaner</b> <ul style="list-style-type: none"> <li>Manual advancement of cleaning ribbon gives operator more control and improved efficiency</li> <li>Open cleaning window with electrostatic dissipative boarder for cleaning multiple connector end faces</li> <li>Microwoven fabric for cleaning ribbon for high performance cleaning</li> <li>Clear side housing for viewing remaining cleaning ribbon</li> </ul> 	Stock to 1 week
POC03M	0000480221	<b>Fiber Optic Splice &amp; Connector Cleaner® Precision Cleaning Fluid</b> <ul style="list-style-type: none"> <li>Air Shippable - Non Aerosol, Non Flammable 85g (3oz) hermetically sealed can</li> <li>Triton Cap - Flip Cap, Side Port and Straw</li> <li>Fast evaporating, No residue engineered specifically for fiber optic &amp; photonic applications</li> <li>Globally GHS and RoHS2 compliant</li> <li>NSN # 6850-01-592-9391 (NATO # 6850-01-592-9440)</li> </ul> 	Stock to 1 week

## Fiber Optic Cleaning Ordering Guide

Sticklers P/N	PREMIER Item #	Description		Standard Lead Time
S12	0000480222	<b>1.25mm CLEANSTIXX™ Cleaning Sticks</b> <ul style="list-style-type: none"> <li>• 50 cleaning sticks per box</li> <li>• 10 sticks per sleeve and 5 sleeves per box</li> <li>• For use with LC, MU, SFP+ modules, ARINC 801 &amp; ODC/RDC (socket termini) connectors</li> <li>• For best cleaning performance, use with Fiber Optic Splice &amp; Connector Cleaner® cleaning fluid P/N POC03M</li> <li>• NSN # 6070-01-553-2267</li> </ul>		Stock to 1 week
S25	0000480223	<b>2.5mm CLEANSTIXX™ Cleaning Sticks</b> <ul style="list-style-type: none"> <li>• 50 cleaning sticks per box</li> <li>• 10 sticks per sleeve and 5 sleeves per box</li> <li>• For use with SC, ST, FC, E2000, OptiTap, MIL DTL 83526 (TFOCA/GFOCA) connectors</li> <li>• For best cleaning performance, use with Fiber Optic Splice &amp; Connector Cleaner® cleaning fluid P/N POC03M</li> <li>• NSN # 6070-01-553-2263</li> </ul>		Stock to 1 week
S16	0000480224	<b>Mil-Aero CLEANSTIXX™ Cleaning Sticks</b> <ul style="list-style-type: none"> <li>• 50 cleaning sticks per box</li> <li>• 10 sticks per sleeve and 5 sleeves per box</li> <li>• For use with MIL DTL 38999 connectors with MIL T 29504/5 socket termini</li> <li>• For use with MIL PRF 28876 connectors with MIL PRF 29504/15 socket termini</li> <li>• For best cleaning performance, use with Fiber Optic Splice &amp; Connector Cleaner® cleaning fluid P/N POC03M</li> <li>• NSN # 6070-01-553-2262</li> </ul>		Stock to 1 week
P25	0000480225	<b>Termini CLEANSTIXX™ Cleaning Sticks</b> <ul style="list-style-type: none"> <li>• 50 cleaning sticks per box</li> <li>• 10 sticks per sleeve and 5 sleeves per box</li> <li>• For use with MIL DTL 38999 connectors with MIL T 29504/4 pin termini</li> <li>• For use with MIL PRF 28876 connectors with MIL PRF 29504/14 pin termini</li> <li>• For use with pin termini in hardened connector systems including MIL DTL 83526 (TFOCA/GFOCA), ARINC 801 &amp; ODC/RDC (socket termini) connectors</li> <li>• For best cleaning performance, use with</li> <li>• Fiber Optic Splice &amp; Connector Cleaner® cleaning fluid P/N POC03M</li> <li>• NSN # 6070-01-553-2258</li> </ul>		Stock to 1 week
XMT	0000480226	<b>MT CLEANSTIXX™ Cleaning Sticks</b> <ul style="list-style-type: none"> <li>• 50 cleaning sticks per box</li> <li>• 10 sticks per sleeve and 5 sleeves per box</li> <li>• For use with MPO/MTP in bulkhead and all other MT based connectors</li> <li>• For best cleaning performance, use with Fiber Optic Splice &amp; Connector Cleaner® cleaning fluid P/N POC03M</li> </ul>		Stock to 1 week
WCS100	0000480227	<b>CLEANWIPES™ 600 Optical Grade Wipes</b> <ul style="list-style-type: none"> <li>• Wipes are good for dry cleaning and wet-dry cleaning</li> <li>• Higher sheer strength wipes prevent lint creation during wipe process</li> <li>• Foil contact layer on top and bottom of cleaning window for static dissipative medium</li> <li>• Color lanes help operator prevent accidental cross contamination</li> <li>• For best cleaning performance, use with Fiber Optic Splice &amp; Connector Cleaner® cleaning fluid P/N POC03M</li> </ul>		Stock to 1 week
WFW	0000480228	<b>CLEANWIPES™ 90 Optical Grade Wipes</b> <ul style="list-style-type: none"> <li>• Wipes are good for dry cleaning and wet-dry cleaning</li> <li>• Higher sheer strength wipes prevent lint creation during wipe process</li> <li>• Hard shell tub protects wipes from spills and cross contamination</li> <li>• For best cleaning performance, use with Fiber Optic Splice &amp; Connector Cleaner® cleaning fluid P/N POC03M</li> <li>• NSN # 7920-01-547-6547</li> </ul>		Stock to 1 week
FA1	0000480229	<b>Outdoor CLEANWIPE™ Optical Grade Wipes</b> <ul style="list-style-type: none"> <li>• Dry, hermetically sealed wipe for use cleaning fiber and fiber optic end faces</li> <li>• Foil inner packaging for static dissipative medium</li> <li>• There are 50 wipes in a bag</li> <li>• For best cleaning performance, use with Fiber Optic Splice &amp; Connector Cleaner® cleaning fluid P/N POC03M</li> </ul>		Stock to 1 week
FOD10A	0000480230	<b>Sticklers® Optic Grade Dust &amp; Particle Remover</b> <ul style="list-style-type: none"> <li>• High purity air stream for cleaning optical components</li> <li>• Non flammable</li> </ul>		Stock to 1 week

Ask your PREMIER Account Representative for more details and place your order today. Call 800-755-1950.

# PREMIER®

## Hand Cleaner Towels

### What are they? How do they work?

PREMIER Hand Cleaner Towels are a unique patented waterless hand-cleaning system. Combining both a high-quality liquid hand cleaner and a heavy-duty, non-scratching, abrasive hand-cleaning towel. This patented towel construction is comprised of a polymeric non-woven soft layer, to which thousands of polymeric deep cleaning scrubbers are permanently bonded to one side of the surface. A special microperforation pattern is added to hold an effective liquid contaminate dissolving agent and soil lifters that dry quickly.

### Who uses PREMIER Hand Cleaner Towels? And where?

Many workers wipe their hands up to 100 times a day without actually cleaning their hands. PREMIER Hand Cleaner Towels can quickly disinfect hands of mechanics, technical service and industrial workers right on location.

### How do PREMIER Hand Cleaner Towels compare to other products?

It is difficult to compare PREMIER Hand Cleaner Towels due to their unique characteristics. PREMIER Hand Cleaner Towels are used for cleaning hands, rather than inadequately wiping them with ordinary shop towels, paper towels, or rags. This is the ideal system for keeping hands professionally clean when soap and water are unavailable.



### Features

- » No rinsing, no drying and no residue
- » Portable
- » Durable Towels
- » Quick Drying Time

Ask your PREMIER Account Representative for more details and place your order today. Call 800-755-1950.



# PREMIER®

## Hand Cleaner Towels

### What types of soil will PREMIER Hand Cleaner Towels actually remove?

Besides normal dirt and soils, PREMIER Hand Cleaner Towels will remove “Icky-PIC”, heavy grease, lubricants, adhesives, oils, tar, asphalt, inks, wax, coal dust, graphite and grass stains. Soils are absorbed into the patented towel and not re-transferred.

### Are They Safe To The User?

PREMIER Hand Cleaner Towels have been tested thoroughly in the field and have undergone independent laboratory testing. They are non-toxic, won't irritate skin and they do not require cautionary statements. PREMIER Hand Cleaner Towels have a flash point in excess of 200°F, and an HMIS flammability rating of one. The polypropylene wiping material and container are fully recyclable (contact your local agencies for details). PREMIER Hand Cleaner Towels are USDA Authorized, and carry an E-4 rating.

### Are PREMIER Hand Cleaner Towels Economical to Use?

Yes. PREMIER Hand Cleaner Towels serve as a very economical addition to any work environment. Significant time and labor savings are realized due to on-site, water-free hand cleaning. These benefits mean that this product becomes an extremely effective cost savings tool in relationship to other cleaning options.

### Description

- Pre-Moistened, Heavy Duty Towel with Pumice Scrubbing Power
- Works Fast to Loosen, Dissolve and Absorb Dirt and Grease
- Contains Germ-Fighting Triclosan
- Conditions and Softens Hands

### Ordering Information

Item Number	Part Number	Description
7333157500	PT-SCRUBS-422C-072	10.5" x 12.125" Towels with 72 PREMIER Hand Cleaner Towels per Bucket

Ask your PREMIER Account Representative for more details and place your order today. Call 800-755-1950.



## Speciality Tools

### PREMIER® Speciality Tools



Terminal Can Wrench



Discrete Connector Presser Plier



Booth Wrench Security Tool

#### PREMIER

Item No.	Mfg. Part No.	Description
0000063993	PT-216C	Terminal Wrench Can Wrench
7463027500	PT-891	Plier - UR/UY Presser
7467817500	PT-532	ScrewDriver - Booth Wrench Security Tool 5/32 inch Hex, 5-1/2-Inches long

## Hand Tools



### Hammers

- Lifetime guarantee on every tool
- Made in the U.S.A.

#### PREMIER

Item No.	Mfg. Part No.	Description
7466417500	51-616	Hammer Curved Claw 16 Ounce Wood Handle
0000022233	56-810	Hammer Sledge 10 Pound

Ask your PREMIER Account Representative for more details and place your order today. Call 800-755-1950.



## Hand Tools



PT-400-SK

### Scissors

- Lifetime guarantee on every tool
- Made in the U.S.A.

#### PREMIER®

Item No.	Mfg. Part No.	Description
0000060425	PT-1964	Nickel Plated Steel Lineman's Scissors with 19 Gauge and 23 Gauge Stripping Notches and Serrated Blade
0000060428	PT-400-SK	Splicers, Kit Consists of Knife, Scissors and Leather Case
0000060427	PT-H11	Leather Pouch for Splicer Kit, Knife and Scissors
0000060426	PT-7	Stainless Steel 6-Inch Splicer Knife



0000091497

### Knives and Blades

- Lifetime guarantee on every tool
- Made in the U.S.A.

#### PREMIER

Item No.	Mfg. Part No.	Description
0000091497	10-175	Knife Retractable Utility with Blade Storage in Handle
0000022252	11-921	Blades Repl F/Utility Knife Straight Blade (Pack Of 5)
0000022256	11-961	Blades Repl F/Utility Knife Hook Blade (Pack Of 5)

Ask your PREMIER Account Representative for more details and place your order today. Call 800-755-1950.



# Hand Tools

## Tape Measures and Levels



Open Fiberglass Tape Measure - 100-Foot



9-Inch Magnetic Torpedo-Style Level

- Lifetime guarantee on every tool
- Made in the U.S.A.

### PREMIER

Item No.	Mfg. Part No.	Description
0000041566	34-790	Tape Open Reel Fiberglass Long 100-Foot
0000022241	43-512	Level 9-Inch Torpedo-Style Magnet



95327



H-11

## Tool Bags and Pouches

- Lifetime guarantee on every tool
- Made in the U.S.A.

### PREMIER®

Item No.	Mfg. Part No.	Description
0000041477	95327	Tool Bag Heavy Duty 24-Inch x 15-Inch
0000060427	H-11	Leather Pouch for Splicer Kit of Splicer Knife and Lineman



J3

## Punches and Chisels

- Lifetime guarantee on every tool
- Made in the U.S.A.

### PREMIER

Item No.	Mfg. Part No.	Description
7471947500	J3	Punch/Chisel Set (5pc) with Plastic Case

# Hand Tools

## Pliers

- Lifetime guarantee on every tool
- Made in the U.S.A.



7463167500



000072151



000072152



000069258



7461467500



000072182



7461067500

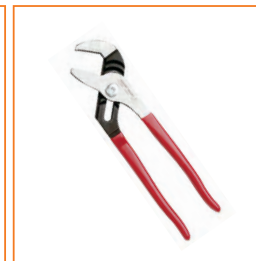

7411237500



7461287500

### PREMIER®

Item No.	Mfg. Part No.	Description
7463167500	225G	Pliers Curved Nose 6 1/4-Inch
000072151	286LN	Pliers Adjustable Locking Straight Long Nose Jaw 6-Inch
000072152	J291R	Pliers Adjustable Locking Straight Jaw 7-Inch
000069258	9INCUTTER	Pliers Cable Cutter 9 1/2-Inch High Leverage
7461467500	PT-842	Pliers Long-Nose with Cutter 6-Inch
000072182	J264SG	Pliers Tongue and Groove 12-Inch
7461067500	PT-942	Pliers Diagonal Cutting with Stripping Notches
7411237500	278G	Pliers Slip Joint 8-Inch
7461287500	PT-683	Pliers Lineman Side Cutters

Ask your PREMIER Account Representative for more details and place your order today. Call 800-755-1950.



# Hand Tools

## Saws and Blades



0000057813

- Lifetime guarantee on every tool
- Made in the U.S.A.

### PREMIER

Item No.	Mfg. Part No.	Description
0000022257	15-808A	Hacksaw Blade 10-Inch 18 Teeth
0000057813	20-556	Wall Board and Drywall Saw

## Screwdrivers



0000041644



0000057680

- Lifetime guarantee on every tool
- Made in the U.S.A.

### PREMIER®

Item No.	Mfg. Part No.	Description
0000041644	66-565	Screwdriver Set Cushion Grip (Set Contains - 3/16" x 6" Cabinet, 5/16" x 6" Standard, 1/4" x 4" Standard, 1pt x 3" Phillips®, 2pt x 4" Phillips, 3/16" x 3" Cabinet)
0000057691	66-096	Screwdriver 3/16" Cabinet 3-Inch Shaft, 6.75" Total Length, Vinyl Grip
0000057692	66-097	Screwdriver 3/16" Cabinet 6-Inch Shaft, 9.75" Total Length, Vinyl Grip
0000057679	65-901	Screwdriver 1 pt Phillips 3-Inch Shaft, 6.75" Total Length, Vinyl Grip
0000057680	65-902	Screwdriver 2 pt Phillips 4-Inch Shaft, 8.5" Total Length, Vinyl Grip
0000057685	66-090	Screwdriver 1/4" Standard 4-Inch Shaft, 8.5" Total Length, Vinyl Grip
0000057686	66-091	Screwdriver 5/16" Standard 6-Inch Shaft, 11" Total Length, Vinyl Grip
0000057687	66-092	Screwdriver 3/8" Standard 8-Inch Shaft, 13.5" Total Length, Vinyl Grip
0000057683	66-088	Screwdriver 1/4" Standard 1.50-Inch Shaft, 3.5" Total Length, Vinyl Grip
0000057682	65-905	Screwdriver 2 pt Phillips 1.50-Inch Shaft, 3.5" Total Length, Vinyl Grip
0000125075	66-168	Screwdriver 3/8" Standard 8-Inch Shaft, 13.25" Total Length
0000057689	66-094	Screwdriver 5/16" Square 6-Inch Shaft, 11" Total Length, Vinyl Grip

# Hand Tools



## Sockets

- Lifetime guarantee on every tool
- Made in the U.S.A.

### PREMIER® STANDARD SOCKETS

Item No.	Mfg. Part No.	Description
0000022227	5249	Socket Drive 3/8-Inch Ratchet 7-Inches Long, Thin Head, Reversing Lever
0000022229	30612	Socket 3/8-Inch Drive, 3/8-Inch 6 Point
0000022230	30614	Socket 3/8-Inch Drive, 7/16-Inch 6 Point
0000022228	30616	Socket 3/8-Inch Drive, 1/2-Inch 6 Point
0000022237	30618	Socket 3/8-Inch Drive, 9/16-Inch 6 Point
0000072166	30620	Socket 3/8-Inch Drive, 5/8-Inch 6 Point
0000072167	30622	Socket 3/8-Inch Drive, 11/16-Inch 6 Point
0000072169	30626	Socket 3/8-Inch Drive, 13/16-Inch 6 Point

### PREMIER DEEP SOCKETS

Item No.	Mfg. Part No.	Description
0000072168	HW1514	Socket 7/16-Inch Deep, 3/8 Drive 6 Point
0000072172	HW-1516	Socket 1/2-Inch Deep, 3/8 Drive 6 Point
0000072173	HW-1518	Socket 9/16-Inch Deep, 3/8 Drive 6 Point
0000072176	HW-1524	Socket 3/4-Inch Deep, 3/8 Drive 6 Point
0000072177	HW-1526	Socket 13/16-Inch Deep, 3/8 Drive 6 Point
0000072174	HW-1520	Socket 5/8-Inch Deep, 3/8 Drive 6 Point

### PREMIER IMPACT SOCKETS

Item No.	Mfg. Part No.	Description
0000072159	7712H	Socket Impact 3/8-Inch Deep, 6 Point
0000072160	7714H	Socket Impact 7/16-Inch Deep, 6 Point
0000072161	7716H	Socket Impact 1/2-Inch Deep, 6 Point
0000072162	7718H	Socket Impact 9/16-Inch Deep, 6 Point

### PREMIER SOCKET SET

Item No.	Mfg. Part No.	Description
0000041462	J52136	Socket Set 3/8 Drive, 12 Point, 22 Piece, Standard
0000072163	1421MNB	Socket Set 1/4 Drive, 6 Point, 21 Piece, Metric

### PREMIER® SOCKET EXTENSIONS

Item No.	Mfg. Part No.	Description
0000072165	34988	Socket 3-Inch Extension 3/8-Inch Drive
0000022231	34987	Socket Extension 3/8-Inch Drive 6 Point

# Hand Tools

## Wrenches



Adjustable Wrench



Wrench Set



Hex Key with Molded Plastic Holder

- Lifetime guarantee on every tool
- Made in the U.S.A.

### PREMIER®

Item No.	Mfg. Part No.	Description
0000550039	90-947	Adjustable Wrench, 6-Inch Black Oxide Finish
0000550391	90-948	Adjustable Wrench, 8-Inch Black Oxide Finish
7462347500	J708G	Adjustable Wrench, 8-Inch
0000550392	90-949	Adjustable Wrench, 10-Inch Black Oxide Finish
7429917500	J712G	Adjustable Wrench, 12-Inch Black Oxide Finish
0000554302	90-950	Adjustable Wrench, 12-Inch
0000022243	BW-1161	Combination Wrench, Box and Open End 7/16-Inch
0000141774	BW-1163FP	Combination Wrench, Box and Open End 9/16-Inch
7469017500	86-837B	Combination Wrench, Box and Open End 5/8-Inch
7469037500	86-839B	Combination Wrench, Box and Open End 3/4-Inch
7469047500	86-840B	Combination Wrench, Box and Open End 13/16-Inch
7469057500	86-841B	Combination Wrench, Box and Open End 7/8-Inch
7469067500	BW-1168	Combination Wrench, Box and Open End 15/16-Inch
0000072178	86-843	Combination Wrench, Box and Open End 1-Inch
0000072179	86-844	Combination Wrench, Box and Open End 1 1/16-Inch
0000072181	86-846	Combination Wrench, Box and Open End 1 1/4-Inch
0000072180	86-845	Combination Wrench, Box and Open End 1 1/8-Inch
0000072157	4980	Hex Key Set, 13 Piece SAE 3/64ths to 3/8ths Graduated by 64ths in Molded Plastic Holder
0000396064	85-450	11-Piece Combination Wrench Set w/ Vinyl Pouch

Ask your PREMIER Account Representative for more details and place your order today. Call 800-755-1950.



# Crimping and Stripping Tools



Ratcheting Crimp Tool

## PREMIER® Ratcheting Crimp Tool

The Ratcheting Crimp Tool is designed for consistent, high quality connections of three types of modular plugs. The triple crimp cavity accommodates 4P, 6P, and 8P modular plugs. The ratcheting mechanism assures consistent, repeatable crimps of the primary strain relief on modular plugs. Both tools cut and strip flat satin cordage, and round cable can be cut and stripped with the newly designed tool. The rubber-embedded handles provide superior leverage and comfort. The steel frame has a black oxide finish to prevent rust and corrosion.

### PREMIER

Item No.	Mfg. Part No.	Description
0000127719	PT-864/UC-864	Ratcheting Crimp Tool for 4 pin 6 pin and 8 pin Modular Plugs (New Design)



PREMIER Coaxial Compression Crimp Tool

## SealTite™ Pro Coaxial Crimper

The SealTite Pro coaxial crimper is a universal tool that preforms a watertight compression crimp on RG59, RG6, and RG6 quad cables. The tool also crimps CATV "F", BNC, and RCA connectors from multiple manufacturers. The crimp height is easily adjustable and can be secured with a locking nut. With the new design, there is no need for separate adapters which are easily misplaced.



Data SureStrip Cable Stripper

## Data SureStrip® Stripper

The Data SureStrip stripper cuts and strips UTP/STP round cable, 25-pair phone cable, and flat satin phone cable. The blade depth easily adjusts with a thumb screw, and then self regulates to prevent nicks to the conductors under the outer jacket.

### PREMIER

Item No.	Mfg. Part No.	Description
0000127988	PT-1116	Stripper for 4 pair and 25 pair Round Cable and Flat Satin Cable

## PREMIER Punch Down Tools

Punch down tool and accessories are for terminating wires onto 110 and 66 type IDC connections.



**PREMIER** Hand Held Termination Tool



Punch Down Tool with 66 Blade



Replacement Double 110 Blade

Item No.	Mfg. Part No.	Description
0000024946	SP-1002P-RD	Punch Down Handheld Termination Tool (Handheld Puck)
7409257501	PT-4572	Replacement 110 Blade For Punch Down Tool
7409027501	PT-4573	Replacement 66 Blade For Punch Down Tool

## PREMIER EZ90 Termination Tool



**PREMIER**

The PREMIER EZ90 solution offers you a cost-effective way of terminating PREMIER voice and data jacks. The PREMIER EZ90 jack design keeps the wires fixed in the terminals before termination. Just one simple squeeze of the handle and the EZ90 tool seats and terminates all wires as well as cuts off the excess wire. The tool's handle lock feature greatly reduces the tool size making it safer and easier to carry and store. The replaceable cutting module design provides for longer tool life and cost savings.

- Time of termination decreased by 85%
- Less force required to terminate versus standard punch down tool
- Convenient termination for any field installation
- Additional cutting module provided for longer tool life
- Light weight, sturdy design

Item No.	Mfg. Part No.	Description
0000227825	PT-EZ90	EZ90 termination tool for EZ90 jacks
0000406458	PT-EZ90-CM	Replacement Cutting Module for EZ90 Termination Tool

Ask your PREMIER Account Representative for more details and place your order today. Call 800-755-1950.



# Marking Paint



Inverted Tip Marking Paint

## Marking and Touch-Up Paint

Marking paints and touch-up paints for every telecom application.

- All of these paints are approved for use in all 50 states
- Marking paints are inverted-tip style for better coverage and easier use
- 12 cans per case, 64 cases per pallet
- Environmentally friendly - no CFC's
- 20 oz. can with 17 oz. net
- 16 oz. can with 12 oz. net

### PREMIER®

Item No.	Mfg. Part No.	Description
7366857500	PT-20-669-PNT-BLU-20	Marking Paint Fluorescent Blue – Water Based (20 oz.)
7366877500	PT-20-668-PNT-GRN-20	Marking Paint Fluorescent Green – Water Based (20 oz.)
7366917500	PT-PNT-ORG-20	Marking Paint Fluorescent Orange – Water Based (20 oz.)
5123497500	PT-PNT-ORG-20-SOLV	Marking Paint Fluorescent Orange Extra Long-Duration – Solvent Based (20 oz.)
7366927500	PT-20-671-PNT-RED-20	Marking Paint Safety Red – Water Based (20 oz.)
7373517500	PT-PNT-WHT-20	Marking Paint White – Water Based (20 oz.)
7366867500	PT-20-678-PNT-YLW-20	Marking Paint Utility Yellow – Water Based (20 oz.)
7361557500	PT-PNT-WAND-33	Marking Paint Applicator
5173047500	PT-98-2-GLWHT-16	Touch-Up Paint Gloss White Enamel (16 oz.)
7394327500	PT-1155-UTILGRN-16	Touch-Up Paint Utility Green Enamel (16 oz.)
0000394874	PT-20-663-PNT-BLK-20	Marking Paint Black Asphalt - Water Based (20 oz.)

Ask your PREMIER Account Representative for more details and place your order today. Call 800-755-1950.



# PREMIER® Durable Outdoor Signs

Durable outdoor signs communicate your important information, identify potential hazards, and help prevent accidents season after season. Use industry standard symbols and headers, or submit your own symbols and messages for a custom solution. We can use pre-approved layouts you provide or create custom artwork for you with headers and graphics that conform to current ANSI/NEMA guidelines.

PREMIER can help you configure the signage solution with the right message, graphics and materials to best meet your needs.

	OUTDOOR DURABILITY	VANDAL RESISTANCE	FEATURES	THICKNESS (inches)	TYPICAL LEAD TIMES
ALUMINUM	10+ years	No	Reflective and non-reflective finishes.	0.025" - 0.080"	3 Weeks
POLYETHYLENE	5-10 years	No	Excellent for indoor / outdoor applications.	0.035" - 0.125"	3-4 Weeks
CO-EXTRUDED POLYETHYLENE	30 years	Yes	Permanently engraved text. Excellent outdoor durability.	0.080"	3-4 Weeks
FIBERGLASS	10-15 years	Yes	Embedded graphics. Easy maintenance.	0.090" - 0.125"	3 Weeks
LEXAN®	10-15 years	Yes	Embedded graphics. Easy maintenance. Graffiti resistant.	0.090"	3-4 Weeks
STEEL/ PORCELAIN	25 years	Yes	Excellent outdoor durability.	0.044" - 0.070"	5-9 Weeks

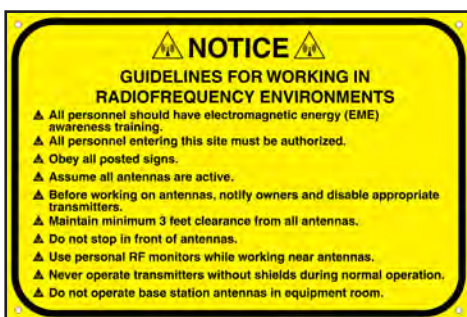
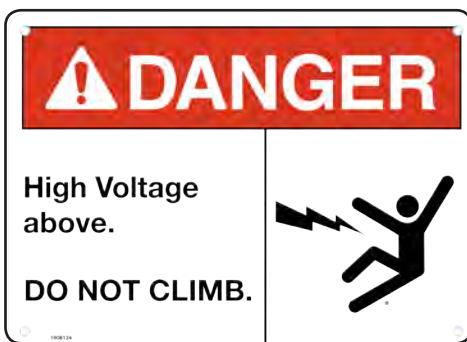

Ask your PREMIER Account Representative for more details and place your order today. Call 800-755-1950.



# Decals, Wire Markers & Signs



Reflective letters and number designed and manufactured to provide long term durability and to adhere in even the most adverse weather conditions. Available in complete kits or individual bags of 25 .

## Also available:

- Wire Markers
- Flex Post
- Dome Post
- Test posts
- Signs
- Decals
- JOISTMATE



# Decals and Tags



Reflective Decal Lettering - Orange

## Reflective Decal Lettering - Orange

Reflective letters and numbers designed and manufactured to provide long-term durability adhere in even the most adverse weather conditions. Characters remain highly visible even at extreme angles, day and night, in all types of weather. Decals are available with black characters on orange backgrounds and conform to ANSI standards.

- Made of the best materials, including 3M backing.
- Packaged in zip locking poly bags. 25 to a package.
- Made in the U.S.A.
- 1 inch x 1.5 inch

### PREMIER®

Item No.	Mfg. Part No.	Description
7333797500	PT-RD-POLE	Pole Marking Holder - Black 3"x14"
7398417500	PT-RD-36KIT-O	Kit of All Letters and Numbers - Orange
7399317500	PT-RD-O-1-BLK/ORG	1
7399327500	PT-RD-O-2-BLK/ORG	2
7399337500	PT-RD-O-3-BLK/ORG	3
7399347500	PT-RD-O-4-BLK/ORG	4
7399357500	PT-RD-O-5-BLK/ORG	5
7399377500	PT-RD-O-7-BLK/ORG	7
7399387500	PT-RD-O-8-BLK/ORG	8
7399367500	PT-RD-O-6/9-BLK/ORG	6 and 9
7399017500	PT-RD-O-A-BLK/ORG	A
7399027500	PT-RD-O-B-BLK/ORG	B
7396927500	PT-RD-O-BLANK-BLK/OR	Blank
7399037500	PT-RD-O-C-BLK/ORG	C
7399047500	PT-RD-O-D-BLK/ORG	D
7399287500	PT-RD-O-DASH	Dash
7399057500	PT-RD-O-E-BLK/ORG	E
7399067500	PT-RD-O-F-BLK/ORG	F
7399077500	PT-RD-O-G-BLK/ORG	G
7399087500	PT-RD-O-H-BLK/ORG	H
7399097500	PT-RD-O-I-BLK/ORG	I
7399117500	PT-RD-O-J-BLK/ORG	J
7399127500	PT-RD-O-K-BLK/ORG	K
7399137500	PT-RD-O-L-BLK/ORG	L
7399147500	PT-RD-O-M-BLK/ORG	M
7399157500	PT-RD-O-N-BLK/ORG	N
7399297500	PT-RD-O-0-BLK/ORG	O and 0
7399167500	PT-RD-O-P-BLK/ORG	P
7399177500	PT-RD-O-Q-BLK/ORG	Q
7399187500	PT-RD-O-R-BLK/ORG	R
7399197500	PT-RD-O-S-BLK/ORG	S
7399217500	PT-RD-O-T-BLK/ORG	T
7399227500	PT-RD-O-U-BLK/ORG	U
7399237500	PT-RD-O-V-BLK/ORG	V

# Decals and Tags

## Reflective Decal Lettering - Orange (continued)

### PREMIER®

Item No.	Mfg. Part No.	Description
7399247500	PT-RD-O-W-BLK/ORG	W
7399257500	PT-RD-O-X-BLK/ORG	X
7399267500	PT-RD-O-Y-BLK/ORG	Y
7399277500	PT-RD-O-Z-BLK/ORG	Z



Reflective Decal Lettering - Yellow

## Reflective Decal Lettering - Yellow

Reflective letters and numbers designed and manufactured to provide long-term durability adhere in even the most adverse weather conditions. Characters remain highly visible even at extreme angles, day and night, in all types of weather. Decals are available with black characters on yellow backgrounds and conform to ANSI standards.

- Made of the best materials, including 3M backing.
- Packaged in zip locking poly bags. 25 to a package.
- Made in the U.S.A.
- 1 inch x 1.5 inch

### PREMIER

Item No.	Mfg. Part No.	Description
7398427500	PT-RD-36KIT-Y	Kit of All Letters and Numbers - Yellow
7398017500	PT-RD-Y-1-BLK/YLW	1
7398027500	PT-RD-Y-2-BLK/YLW	2
7398037500	PT-RD-Y-3-BLK/YLW	3
7398047500	PT-RD-Y-4-BLK/YLW	4
7398057500	PT-RD-Y-5-BLK/YLW	5
7398077500	PT-RD-Y-7-BLK/YLW	7
7398087500	PT-RD-Y-8-BLK/YLW	8
7398067500	PT-RD-Y-6/9-BLK/YLW	6 and 9
7398117500	PT-RD-Y-A-BLK/YLW	A
7398127500	PT-RD-Y-B-BLK/YLW	B
7398397500	PT-RD-Y-BLANK	Blank
7398137500	PT-RD-Y-C-BLK/YLW	C
7398147500	PT-RD-Y-D-BLK/YLW	D
7398387500	PT-RD-Y-DASH-BLK/YLW	Dash
7398157500	PT-RD-Y-E-BLK/YLW	E
7398167500	PT-RD-Y-F-BLK/YLW	F
7398177500	PT-RD-Y-G-BLK/YLW	G
7398187500	PT-RD-Y-H-BLK/YLW	H
7398197500	PT-RD-Y-I-BLK/YLW	I
7398217500	PT-RD-Y-J-BLK/YLW	J
7398227500	PT-RD-Y-K-BLK/YLW	K
7398237500	PT-RD-Y-L-BLK/YLW	L

## Decals and Tags

### Reflective Decal Lettering - Yellow (continued)

#### PREMIER®

Item No.	Mfg. Part No.	Description
7398247500	PT-RD-Y-M-BLK/YLW	M
7398257500	PT-RD-Y-N-BLK/YLW	N
7398097500	PT-RD-Y-0-BLK/YLW	O and 0
7398267500	PT-RD-Y-P BLK/YLW	P
7398277500	PT-RD-Y-Q-BLK/YLW	Q
7398287500	PT-RD-Y-R-BLK/YLW	R
7398297500	PT-RD-Y-S-BLK/YLW	S
7398317500	PT-RD-Y-T-BLK/YLW	T
7398327500	PT-RD-Y-U-BLK/YLW	U
7398337500	PT-RD-Y-V-BLK/YLW	V
7398347500	PT-RD-Y-W-BLK/YLW	W
7398357500	PT-RD-Y-X-BLK/YLW	X
7398367500	PT-RD-Y-Y-BLK/YLW	Y
7398377500	PT-RD-Y-Z-BLK/YLW	Z

Ask your PREMIER Account Representative for more details and place your order today. Call 800-755-1950.



# PREMIER® Safety Wipes – Sunscreen Wipes and Insect Repellent Wipes

## PREMIER® Sunscreen Wipes

PREMIER Sunscreen Wipes combine a unique liquid sunscreen formula and a large, lint-free wipe. The wipe will remain open and retain its original size while applying to the face, neck and arms. PREMIER Sunscreen delivers full sun protection for professionals who work in the outside environment. This formula is waterproof and greaseless.



### Features and Benefits

- » SPF 30+
- » Water/Sweat Resistant
- » Non-greasy
- » UVA/UVB Protection
- » Aminobenzoic Acid [PABA] - free
- » Safe on Rubber Gloves (Passed Lineman's Glove Testing Type 1 Class 2 ANSI/ASTM-D412)
- » Sun Alert: Limiting sun exposure, wearing protective clothing and using sunscreens may reduce the risks of skin aging, skin cancer and other harmful effects of the sun.

#### Sunscreen Wipes

Item Number	Part Number	Description
0000286175	PT-9120182900	Sunscreen Wipes SPF30+ Pkg of 25

## SCRUBS® INSECT SHIELD™ Insect Repellent Wipes

SCRUBS® INSECT SHIELD™ Insect Repellent Wipes feature an insect Repellent formula combined with a large, lint-free wipe. The 30% DEET insect Repellent formula provides a safe, yet highly effective level of protection. The wipe allows for a one-step, controlled application with no worry of inhaling mist or vapors. Once applied, the formula is waterproof and greaseless so it won't interfere with activities or tasks. Each wipe is individually packaged, making it easy and convenient to carry or store.



\* Do not apply product near eyes and mouth.

### Features and Benefits

- » 30% DEET
- » Easy Application
- » Non-greasy
- » Waterproof Formula
- » Long Lasting Protection
- » Effective against: Mosquitoes, Ticks, Chiggers, Flies, Fleas and No-See-Ums

#### SCRUBS® INSECT SHIELD™ Insect Repellent Wipes

Item Number	Part Number	Description
0000286174	9140182900	Insect Shield Wipes 30% DEET Pkg of 25

Ask your PREMIER Account Representative for more details and place your order today. Call 800-755-1950.



# PREMIER® Splice Protection Sleeves

## Product Overview

Protection Sleeves Length: 40mm, 60mm.

Steel needle Diameter: 1.2mm

- (1) Splice point protection
- (2) External tube clearly showing the status of connection
- (3) Airproof configuration keeping the splice point's good resistance of humidity and temperature
- (4) Operating temperature ranging from -45°C to 100°C

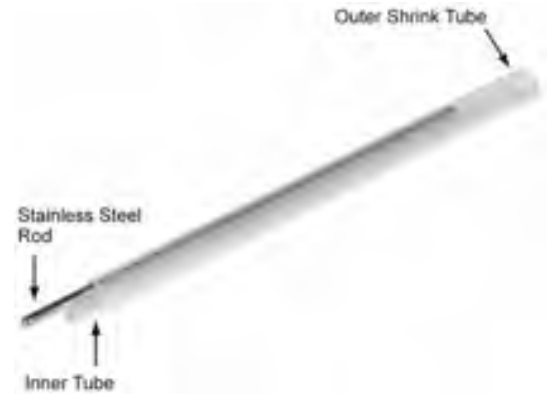

1 – Outer Tubing 2 – Strength Member 3 – Inner Tubing

## Moisture resistant for environmental protection:

- (1) Consist of cross-linked polyolefin, hot fusion tubing and stainless reinforced steel rod.
- (2) Maintains optical transmission performance.
- (3) Provides protection for fiber splicing.
- (4) No damage to the optical fiber during installation.

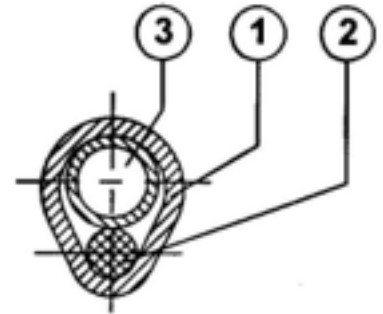

## Features

- » Single hole (preshrunk) ends eliminates improper fiber threading
- » Smooth, deburred stainless steel reinforcing member ends decrease the risk of fiber damage during installation
- » Extended liner length prevents contact between the fiber and the backbone
- » Clear sleeve design per sign permits easy centering of splice before heating
- » Sealing structure makes the splice free from effect of temperature and humidity from environment
- » Minimum fully recovery temperature: 120 °C
- » Designed to restore complete environmental and mechanical integrity of coating or buffer of optical fiber after splicing.
- » Sleeves are manufactured using state of the art machines and controlled manufacturing environment in an ISO 9001 certified manufacturing facility.
- » Outer tube conforms to MIL-I 23053/5 class 2 standards.
- » Hot melt adhesive tube made from polyolefin Ethyl Vinyl Acetate copolymer bonds both to the fiber and heat shrinkable outer tube to effectively encapsulate fusion splice.
- » Strength member is made from “Full hard” stainless steel of 304 grade and is ground at the edges before polishing to make it completely burr free to avoid rupturing during shrinking. 304 grade gives better corrosion resistance, even in coastal environment. Resistant to heat shocks, no cracking dripping or flowing.
- » Long term proven performance, exceeds industry standards.

## Ordering Information

Item Number	Part Number	Description
0000505729	PT-FO-SLEEVE-40MM	Fusion Splice Sleeve, 40MM
0000505730	PT-FO-SLEEVE-60MM	Fusion Splice Sleeve, 60MM
0000547022	PT-FO-SLEEVE-R12S-40MM	12 Ribbon Splice Sleeve 40mm Single Ceramic 50/BG

Ask your PREMIER Account Representative for more details and place your order today. Call 800-755-1950.



# Splicing Supplies



PREMIER Vinyl Tape - Assorted Colors

## Tape

- Premium vinyl all-weather electrical and telephone tape
- Approved by UL and CA
- Tested for temperatures up to 105° C
- For uses up to 600 volts
- Black is 8.5 mil.
- Colors are 7 mil.

### PREMIER®

Item No.	Mfg. Part No.	Description
0000088933	PT-88 TAPE 3/4X36	Black Vinyl Tape 3/4-Inch x 36-Feet
0000088932	PT-88 TAPE 1X36	Black Vinyl Tape 1-Inch x 36-Feet
0000088934	PT-88 TAPE 1-1/2X44	Black Vinyl Tape 1 1/2-Inch x 44-Feet
0000088935	PT-88 TAPE 3/4X60	Black Vinyl Tape 3/4-Inch x 60-Feet
0000126721	PT-35 TAPE 3/4X66BLU	Blue Vinyl Tape 3/4-Inch x 66-Feet
0000088941	96418	Brown Vinyl Tape 3/4-Inch x 66-Feet
0000088926	92798	Gray Vinyl Tape 3/4-Inch x 66-Feet
0000126723	PT-35 TAPE 3/4X66GRN	Green Vinyl Tape 3/4-Inch x 66-Feet
0000088939	96416	Orange Vinyl Tape 3/4-Inch x 66-Feet
0000126722	PT-35 TAPE 3/4X66RED	Red Vinyl Tape 3/4-Inch x 66-Feet
0000088936	PT-35 TAPE 3/4X66YEL	Yellow Vinyl Tape 3/4-Inch x 66-Feet

## Miscellaneous Tape

### PREMIER

Item No.	Mfg. Part No.	Description
0000201924	PT-97374	Tape Do Not Climb 1-Inch x 72-Yards yellow Printed UNSAFE DO NOT CLIMB
0000200247	PT-3939	Tape Duct 2-Inch x 60-Yards, 9 mil
0000200245	BB7-91500	Tape Glass 1-Inch x 108-Feet
0000088931	96205	Tape Vinyl Mastic 1 1/2-Inch x 20-Feet
0000200250	PT-49-4X40	Tape Aluminum 4-Inch x 40-Feet

Ask your PREMIER Account Representative for more details and place your order today. Call 800-755-1950.



# Truper Tools from PREMIER®

PREMIER offers a premium line of contractor grade tools, geared toward the customer who recognizes the value in high-end tools. Truper Tools from PREMIER offer the best value at the top end of the market.

## Tru Pro Professional Grade digging tools feature:

- » 9 Inch soft cushioned grip
- » Fiberglass handles with 0.11 Inch wall thickness
- » Steel insert in handles provide up to 400 pounds of handle strength in dynamic load tests
- » Rivetless steel ring connect shovel neck and handle making it one solid unit
- » 14 gauge heads



## Tru Tough Landscaper Grade digging tools feature:

- » American Ash wooden handles
- » Turned steps
- » Steel collar reinforcement plus rivets securing handles to heads
- » Steel and wood D Grips have seamless electronic welds and double riveted heavy gauge braces
- » 16 gauge heads



## Tru Pro Professional Grade Long Handled California Trenching Shovels Feature:

- » 47 Inch American Ash Wooden Handles
- » Turned Steps
- » 2-piece construction blades provide optimum trenching angle and leverage
- » Rivets securing heads to handles
- » 13 gauge heads



## Heavy Duty Digging and Tamping Bars feature:

- » Drop forged and tempered construction
- » Superior strength for prying, digging, and tamping
- » 16 lb.
- » Rust resistant black finish



## Snow Shovel features:

- » 36 Inch Steel Handle with D style grip
- » Mid sleeve grip to insulate hands in cold weather
- » 18-Inch-wide aluminum blade
- » Galvanized metal wear strip on blade



## Ordering Information

Tru Pro Professional Grade digging tools		
Item Number	Part Number	Description
0000475720	31198	Round Point Shovel with 48 Inch Fiberglass Handle
0000475721	31200	Round Point Shovel with 29 Inch Fiberglass D Style Grip
0000475722	31199	Square Point Shovel with 48 Inch Fiberglass Handle
0000475723	31201	Square Point Shovel with 29 Inch Fiberglass D Style Grip
0000475724	31286	Drain Spade, 16 Inch, 48 Inch Fiberglass Handle
0000475725	31285	Drain Spade, 16 Inch, 29 Inch Fiberglass D Style Grip
0000475726	33437	Trenching Shovel, 5 Inch, 48 Inch Fiberglass Handle
0000475727	31380	Bow Rake, 16 Tines, 60 Inch Fiberglass Handle
0000439505	CA-38F	Post Hole Diggers, 48 Inch Fiberglass Handles, Inch Markings
Tru Tough Landscaper Grade digging tools		
0000475728	33037	Shovel, Round Point, 48 Inch Wooden Handle
0000475729	31185	Shovel, Round Point, 30 Inch Wooden Handle, Steel D Style Grip
0000475730	33041	Shovel, Square Point, 48 Inch Wooden Handle
0000475731	31187	Shovel, Square Point, 30 Inch Wooden Handle, Steel D Style Grip
0000475732	31284	Drain Spade, 30 Inch Wooden Handle, Steel D Style Grip
0000475733	33038	Bow Rake, 16 Tines, 54 Inch Wooden Handle
Tru Pro Professional Grade Long Handled California Trenching Shovels		
0000475734	33107	Trenching Shovel, 3 Inch Blade
0000475735	33094	Trenching Shovel, 4 Inch Blade
0000475736	33095	Trenching Shovel, 5 Inch Blade
0000475737	33096	Trenching Shovel, 6 Inch Blade
Heavy Duty Digging and Tamping Bars		
0000475718	30106	Bar, Heavy Duty, San Angelo 1 Inch, Hexagonal Section, 16 Pound, BAP-175
0000475719	30162	Bar, Heavy Duty, Post Hole Digging/Tamping, 16 Pound, TB-175
Snow Shovel		
0000475717	33816	Snow Shovel, Aluminum, 18 Inch

Ask your PREMIER Account Representative for more details and place your order today. Call 800-755-1950.



# Bonide® from PREMIER

## Wasp and Hornet Killer

Bonide Wasp and Hornet Killer is specially formulated to provide instant knockdown and quick kill of wasps and hornets from up to 20 feet away. Residual action will also prevent re-nesting.

Get more product per can with Bonide Wasp and Hornet Killer 15 oz. net contents can. For best results, spray in the early morning or late evening when insect activity is minimal.



### Features

- » Kills wasps, hornets, and carpenter bees
- » Instant knock down
- » Quick kill
- » Residual action prevents re-nesting
- » Sprays up to 20'
- » Dielectric breakdown voltage of 47,300 volts
- » 15 oz. net contents per can

### Ordering Information

Item Number	Part Number	Description
0000391496	631	Wasp and Hornet Spray 20 oz. can, 15 oz. net

Ask your PREMIER Account Representative for more details and place your order today. Call 800-755-1950.



# PREMIER®

## Wireless Weatherproofing Kit

The PREMIER Wireless Weatherproofing Kit can be used to create an environmental seal for connections found at wireless infrastructure sites. The tapes also help prevent the loosening of connections caused by vibrations. The kit is excellent for cold weather applications.

### Kit Contents:

- » 6 rolls butyl mastic tape (2.5 in. x 24 in.)
- » 1 roll black vinyl tape (2 in. x 20 ft.)
- » 2 rolls black vinyl tape (3/4 in. x 66 ft.)
- » Installation Instructions



Ask your KGPCo Customer Service Representative for more details and place your order. 800-755-1950

### Wireless Weatherproofing Kit

Item No.	Mfg. Part No.	Description
0000406459	PT-WWP-Kit	6 Rolls Butyl Mastic Tape 2.5"x24" 1 Roll Black Vinyl Tape 2"x20' 2 Rolls Black Vinyl Tape 3/4"x66'

# Tracer Wire

» Pro-Trace Tracer Wire





# Pro-Trace **TRACER WIRE**



## Pro Trace HF-CCS

Designed with the Flexibility, memory, and feel of copper, and 43% higher break load. This CCS tracer wire is equal in signal performance, and cost less than traditional copper tracer wire.

High Flex Copper Clad Steel

AVAILABLE IN:  
30 MIL HDPE & 45 MIL HDPE

WIRE GAUGE:  
18, 16, 14, 12, 10 & 8 AWG

LENGTH:  
500', 1000', 2500'

## Pro Trace HDD-CCS

PRO-TRACE<sup>®</sup> HDD-CCS PE45 conductor is equal to Copper in signal tracing performance for tracer wire applications not exceeding 600 Vols. Tracer wire is used to conductively locate buried utility lines for gas, water, sewer, telecommunications, and electrical markets.

Horizontal Directional  
Drilling Copper Clad Steel

AVAILABLE IN:  
45 MIL HDPE

WIRE GAUGE:  
14, 12, 10, 8 AWG & 4 STR

LENGTH:  
500', 1000', 2500'

## Pro Trace HS-CCS

A high carbon steel core, metallurgically bonded with a copper cladding, that is uniform and continuous, creating a bi-metal conductor that acts as one and is corrosion resistant. Special annealing processes are performed during the cladding process to giving HS-CCS twice the tensile strength and significantly reducing line breakage experienced with copper trace wire.

High Strength Copper Clad Steel

AVAILABLE IN:  
30 MIL HDPE & 45 MIL HDPE

WIRE GAUGE:  
14, 12, 10, 8 AWG & 4 STR

LENGTH:  
500', 1000', 2500'

Contact the PREMIER team for complete products and pricing.

PREMIER@kgpco.com or (800) 755-1950